

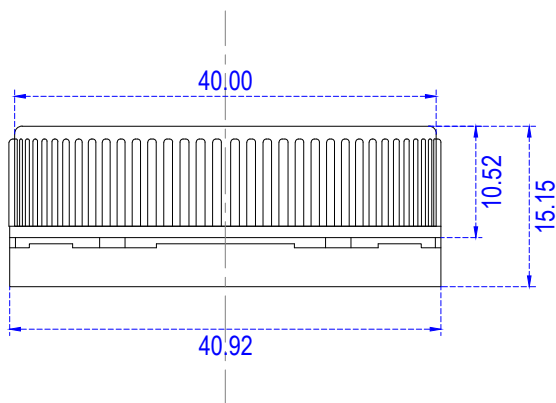

## HDPE CAP 38 MM

- Odorless, Tasteless, Hygienic, Stable
- Suitable for direct-contact, Secondary food packaging
- Recyclable, Environmentally friendly
- Cost-effective



### Properties

Material	:HDPE
Material composition	:98% HDPE 2% Master Batch
Manufacturing Process	:Injection molding
Rim Diameter (mm)	:40.92
Total height (mm)	:15.15
Product Weight (g)	:2.7/3.5
Color(s)	:Multi color, on demand
Application	:Cold use
Microwavable	:No
Freezer compatible	:Yes
Dishwasher safe	:No
Number of uses	:Single
Softening Temperature (°C)	:120
Upper Temperature Limit (°C)	:80
Lower Temperature Limit (°C)	:-40
Printable	:No

### Packaging

Packaging	:Cardboard Carton
Pieces per Carton	:3000    3000
Carton Width (cm)	:60    60
Carton Depth (cm)	:42    42
Carton Height (cm)	:40    40
Carton Weight (Kg)	:9.35    11.75

### Storage & Handling Conditions

Dry Cool Space (<40°C)  
Out of Direct Sunlight  
Maximum stacking 5 Cartons

### Ordering Option(s)

Unprinted / Printed  
2.7/3.5 g

### Quality

All our products are produced in quality controlled environment taking into consideration food safety and hygiene standards under certified ISO 9001:2000 & ISO 9001:2008 and GMP quality management system. Our Quality System is regularly audited by third party.



### Disclaimer

Consumer Safety is extremely important for Industrium. Therefore all our food-contact materials and articles are produced taking into consideration national and international regulations, and do not transfer their constituents to the food under normal or foreseeable conditions of use. The foregoing data are without engagement and constitute the best of our knowledge; they are reliable if applied correctly and adapted to local conditions and cannot be taken as any guarantee, since the processing at the end-user are beyond our control. The above mentioned guidelines are supplied to assist the buyer in determining the proper use of products. However, because every food supplier's recipes, ingredients, processes and supply chain are unique, these guidelines are not a substitute for product testing. Confirmation of product acceptability under customer's specific conditions of use must be done by the customer.